



VP E 04 2017 • © Frenco GmbH



# Gear testing instruments with face stop

Measurement of the dimension  
between or over two balls

 *pure  
perfection*

**FRENCO**

## Measuring with Face Stop

VP gear testing instruments feature a face stop. Finding the reversal point is no longer required.

Specimens with a usable end face are placed on the table of the instrument and measured at right-angles without reversal point.

The measuring stilts of the VP instruments can be rotated and moved. They are universally suitable for both internal and external profiles with small or large diameters.

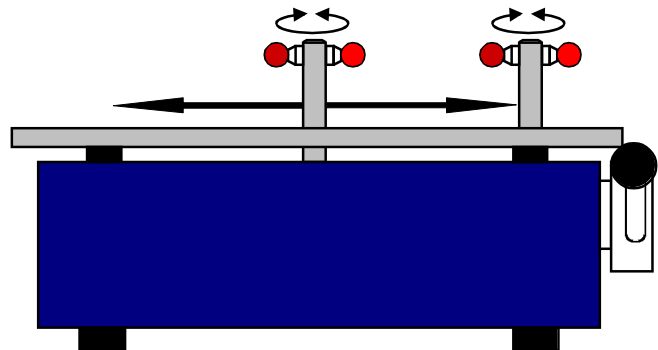
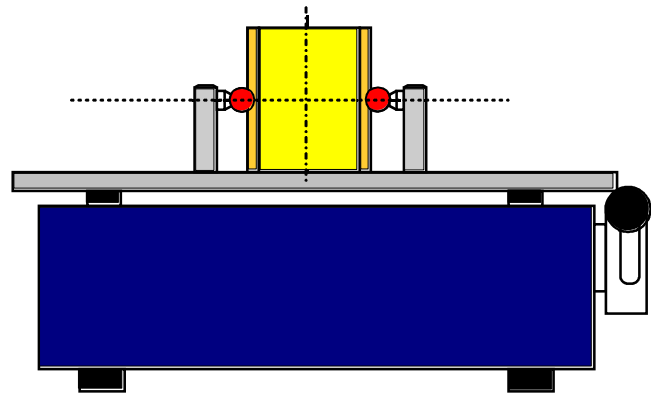

A **setting plug or ring** is needed for calibration. The spline or gear profile has to equal the specimen.







### Features:

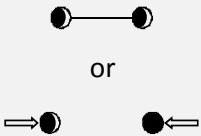

- The measuring results are not reliant on the operator.
- Measurements are always carried out at right-angles to the work-piece axis.
- Different sizes, types and diameters of gears and splines can be measured with one instrument.
- Measuring helical profiles is possible.
- Wear of the measuring inserts can be compensated for through calibrations with a setting master.
- Measurement is possible in any number of planes (VPE only).

## Product Overview

|      | Type & Picture  | Pitch circle diameter                                       |
|------|---|---|
| VPO  |    | External gear up to 100 mm<br>Internal gear up to 120 mm    |
| VPE  |    | External gear up to 200 mm<br>Internal gear up to 220 mm    |
| VPOS |   | For shafts with external gearing up to 250 mm               |
| VPO3 |  | External gear up to 250 mm<br>Internal gear 90 mm to 320 mm |

|                         |   |   |
|-------------------------|---|---|
| Measured value display  |  | Analogue dial indicator                   |
|                         |  | digital                                   |
| Radial measuring points |  | Two opposite-lying for inside and outside |
| Axial measuring planes  |  | static                                    |
|                         |  | dynamic                                   |

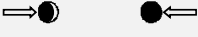
## Gear Testing Instrument VPO

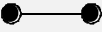
| Measured value display  | Radial measuring points   | Axial measuring planes  |
|---|---|---|
|  |  |  |
| 88  |  |   |

The VPO is a simple gear testing machine to determine the diametrical size over two balls in **one** specific measuring plane. It can be refitted within a few minutes and is particularly suitable for quick measurements of small pieces up to a PCD of 120 mm.

The balls are mounted on a movable and a fixed carriage. To change the workpiece, the movable carriage can be retracted using the lever on the front. To display the measuring results both a dial indicator or a digital probe can be used.







Gear testing instrument VPO

### Technical specifications VPO

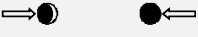
|                             |                                  |
|-----------------------------|----------------------------------|
| External gears              | up to 100 mm PCD                 |
| Internal gears              | from 120 mm PCD                  |
| Measuring force             | infinitely adjustable up to 10 N |
| Dimensions (without stilts) | 185x180x58 mm                    |
| Weight approx.              | 3.3 kg                           |

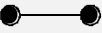
## Gear Testing Instrument VPE

| Measured value display  | Radial measuring points   | Axial measuring planes  |
|---|---|---|
|  |  |  |
| 88  |  |  |

The VPE is a gear testing machine to determine the diametrical size over two balls in any number of planes. It can be refitted within a few minutes and is mainly used for quick measurements of pieces with a PCD up to approx. 220 mm.





Measuring device VPE

### Technical specifications

|                             |                                  |
|-----------------------------|----------------------------------|
| External gears              | up to 200 mm PCD                 |
| Internal gears              | up to 220 mm PCD                 |
| Vertical travel             | 30 mm                            |
| Measuring force             | infinitely adjustable up to 10 N |
| Dimensions (without stilts) | 340x210x118 mm                   |
| Weight approx.              | 11 kg                            |

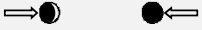
# Gear Testing Instrument VPOS

| Measured value display  | Radial measuring points   | Axial measuring planes  |
|---|---|---|
|  |  |  |
| 88  |   |   |

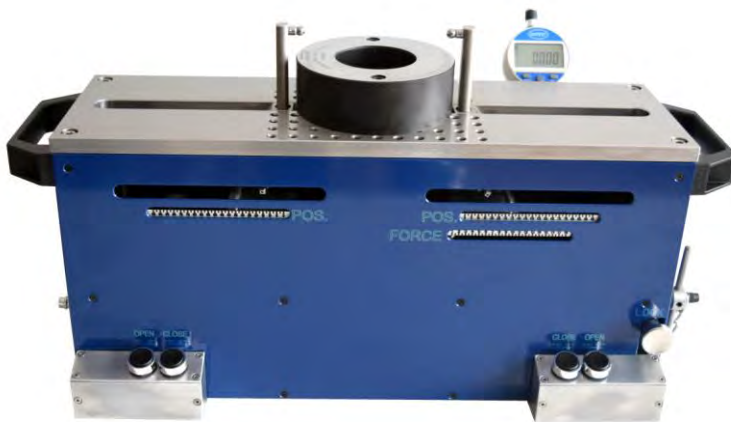

The VPOS instrument was designed to measure the dimension over/between balls on large workpieces and splined shafts.

Great importance was given to functionality, optical characteristic and easy handling to ensure that, besides precision and accuracy, a comprehensive objective was achieved. The positioning of the stilts is performed pneumatically, and the feed mechanically dampened. To increase safety, the device can be operated in two-hand mode. The measuring force can be adjusted to the workpiece weight quickly and easily via the lever.

The VPOS is easy to operate and a stable table-top instrument to be used on the shop floor

## Technical Specifications

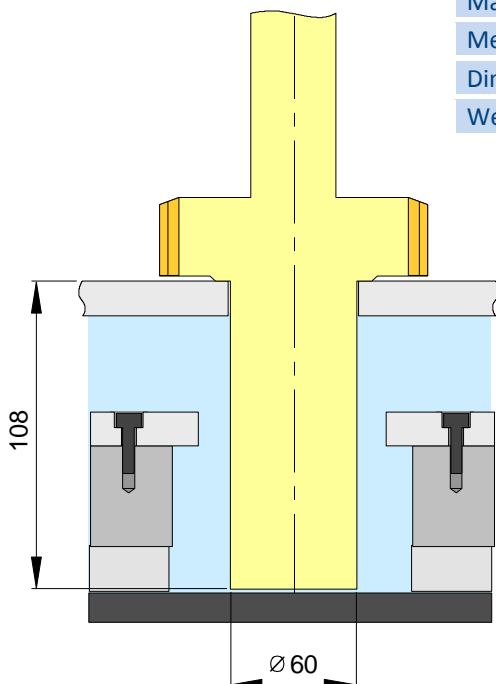

|                            |   |
|----------------------------|---|
| External gears             | Dimension over balls: 75 - 260 mm               |
| Max. shaft diameter        | up to $\varnothing 60$ mm (in standard version) |
| Max. shaft shoulder length | up to 108 mm (extendable)                       |
| Measuring force            | infinitely adjustable up to 15 N                |
| Dimension (without stilts) | 340x210x118 mm                                  |
| Weight approx.             | 25 kg   |



Lever to infinitely adjust the measuring force

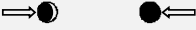

# Gear Testing Instrument VPO3

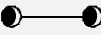
| Measured value display  | Radial measuring points   | Axial measuring planes  |
|---|---|---|
|  |  |  |
| 88  |  |   |

Gear testing instrument VPO3

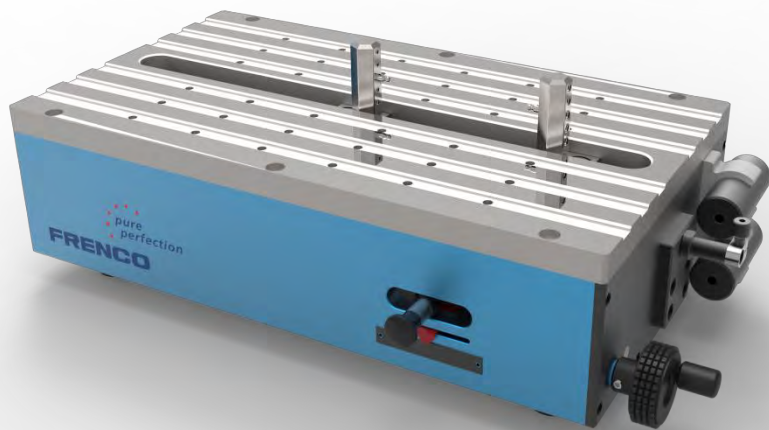











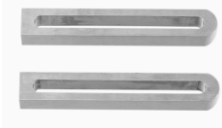

Our new device for the manual measurement of the dimension over balls DOB of large workpieces.

- Reduction of the measuring force by tilting the device
- Holding position of the measuring stilts for easy loading and unloading
- Metro Touch Display for quick results and PC interface for data export
- Integration of a thermostat possible

| Technical Specifications                        |                          |
|---|--------------------------|
| DOB external gears                              | ca. 0 - 250 mm           |
| DOB internal gears                              | ca. 90 - 320 mm          |
| Measuring force                                 | 5 - 20 N                 |
| Measuring pin threads                           | M2,5 oder M4             |
| Dimensions (without stilts and measuring probe) | 360 mm x 200 mm x 110 mm |
| Weight  | 20 kg                    |

## Accessories

|   |   |
|---|---|
| Stilts 35 mm for measuring ball inserts M2.5 or M4 or for Mahr inserts  |    |
| Stilts 60 mm for measuring ball inserts M2.5 or M4 or for Mahr inserts  |    |
| Stilts 35 mm for measuring pin inserts  |    |
| Stilts 60 mm for measuring ball inserts   |    |
| Measuring ball inserts tungsten carbide available in 1 micron steps, with M2.5 (from Ø1-7 mm) or M4 thread (from Ø7 mm) |    |
| Measuring pin inserts, rocking and rotating   |   |
| Stop prisms for easier mounting of workpieces   |   |
| FRENCO dial indicator with eccentric zero point   |  |
| Probe with "Heidenhain" display   |  |
| Setting rings and plugs   |  |
| Centering support   |  |
| Setting master for measuring height   |  |

# Frenco Product Range



## High Precision Gears and Splines H

Gear and Spline Gauges  
Master Gears, Master Wheels  
Artefacts, Masters  
Punches, Dies & Electrodes  
Profiled Clamping Systems  
Gear and Spline Manufacture



## Rotation Measuring Systems R

Instruments with Measuring Circles  
Multiple Inspector  
Gear Flank Analysing  
Linear Gear Flank Analyser Rack  
Gear Flank Analyser  
Double Flank Gear Roll Inspection



## Instruments for Size Inspection Series V

Measuring Pins and Ball Inserts  
Instruments, Rocking Type  
Instruments with Face Stop  
Instruments with Guiding Profiles  
Circumferential Backlash Instrument  
Customized Solutions



## Gear & Spline Inspection P

DAkKS-Calibration  
Monitoring of Inspection Equipment  
Workpiece Inspections  
Analysis of Deviations



## Know-How-Transfer K

Software  
Training, Seminars, Workshops  
Consulting and Calculations  
Literature and Documentations  
National and International Standards



# FRENCO

**Frenco GmbH**  
**Gear + Spline Technology**

Jakob-Baier-Straße 3  
90518 Altdorf, Germany

Tel.: +49 (0) 9187 - 95 22 0  
Fax: +49 (0) 9187 - 95 22 40  
E-Mail: [frenco@frenco.de](mailto:frenco@frenco.de)

